

# **406**

*Coupé*

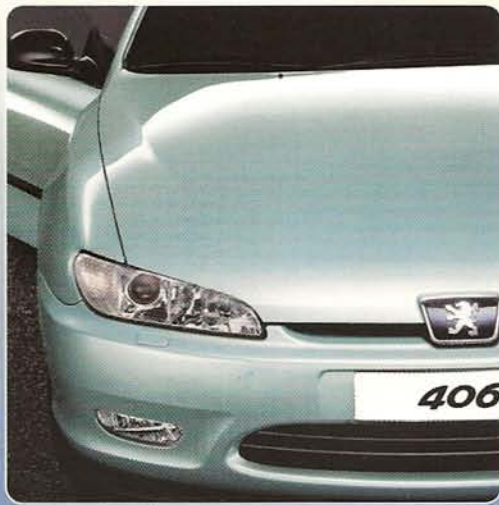

**PEUGEOT**



## BEAUTY AND BRAINS

Just one glance and you'll appreciate a sublime beauty, an effortless perfection of line. Carrying the distinguished signatures of Peugeot and Pininfarina, the 406 Coupé inherits the proud traditions of the marque's legendary *coupés de ville*. But, as never before, beauty is combined with brains. In the 406 Coupé, the bespoke feel of the car is complemented by advanced new technologies - harnessed to keep you firmly in control of an outstanding driving experience. If you like cars, you'll love the 406 Coupé.

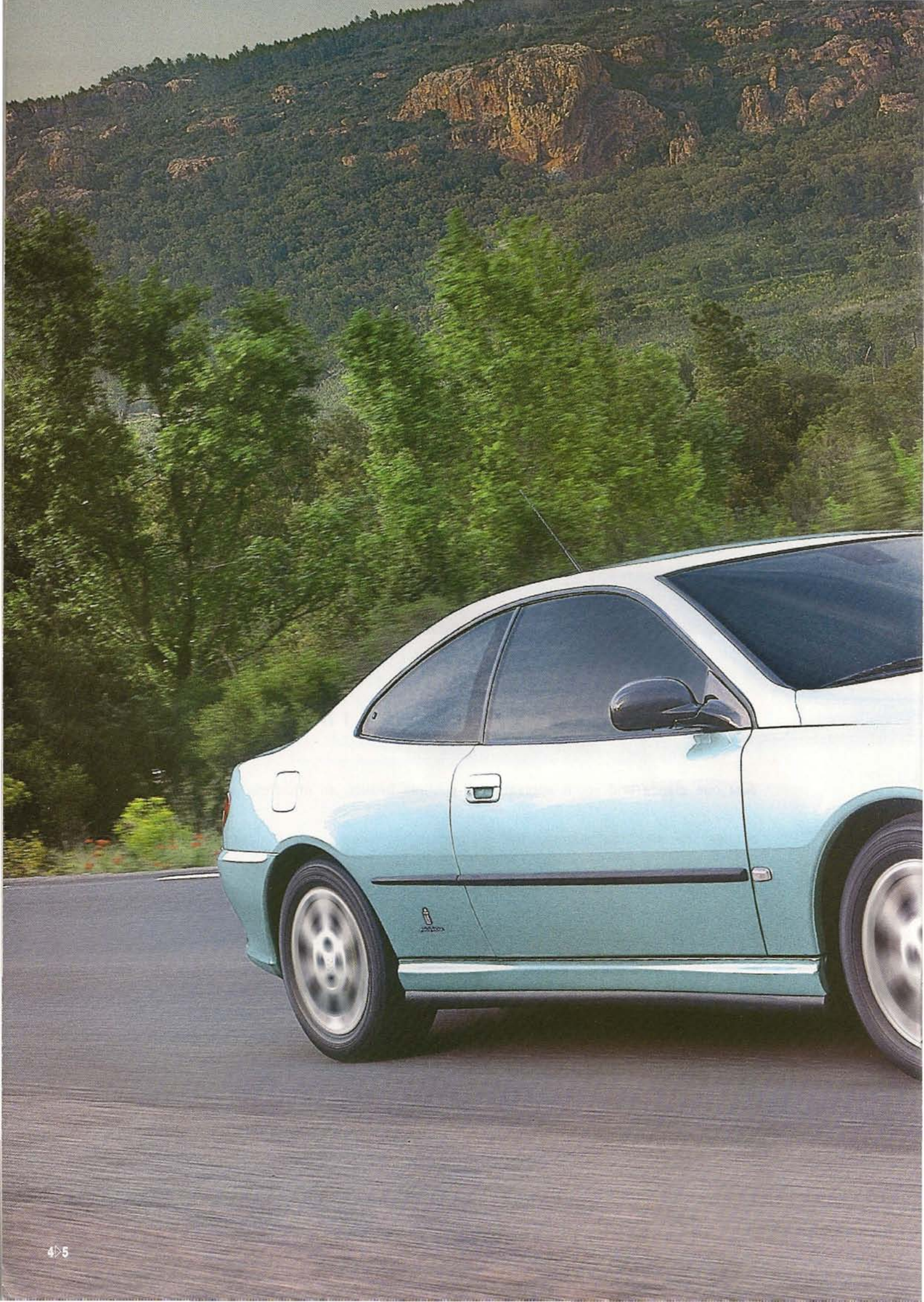



A high-angle, rear-quarter view of a light blue Peugeot car. The image shows the rear window, a side mirror, the rear door, and the rear bumper. The word "PEUGEOT" is visible on the rear door. The car is set against a dark background.

## MORE THAN A TOUCH OF INSPIRATION

A subtle balance of elegance and restrained aggression is emphasised by the inspired proportions of swooping bonnet, sharp boot, sensual curves and flowing wings. Every detail combines to create a vibrant, powerful impression. The body

sides neatly enclose the rear screen, the clear-lens headlamps are smoothly feline, and the bold sweep of the heat-reflecting windscreen clearly means business. In the 406 Coupé, timeless style goes hand in hand with the technology of tomorrow.

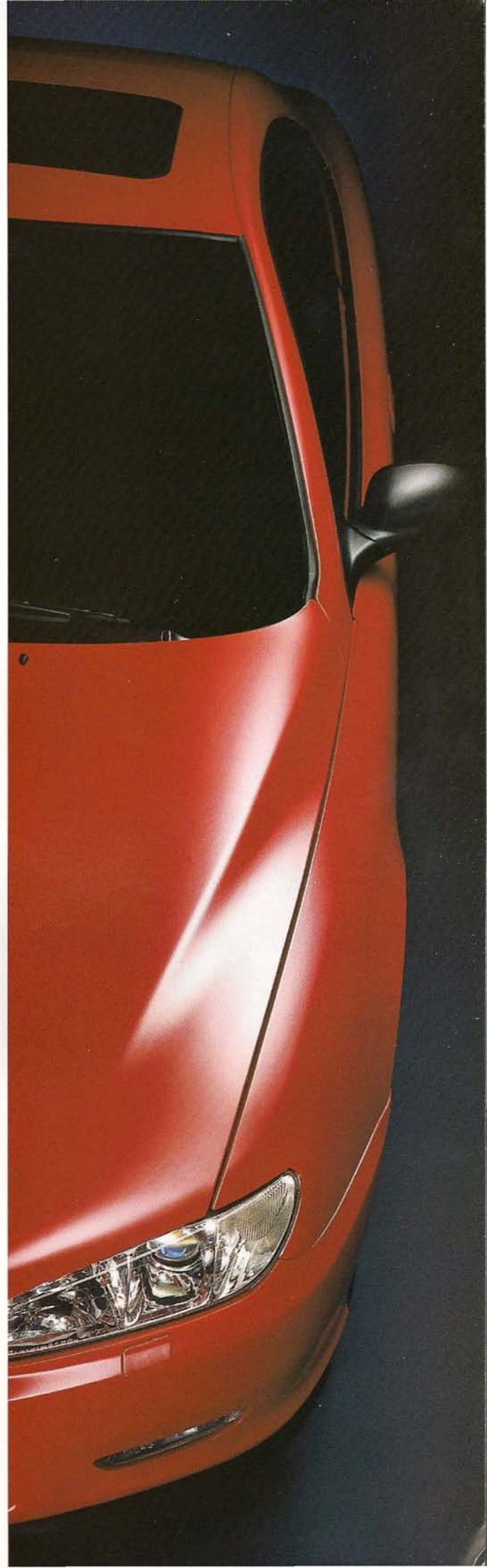







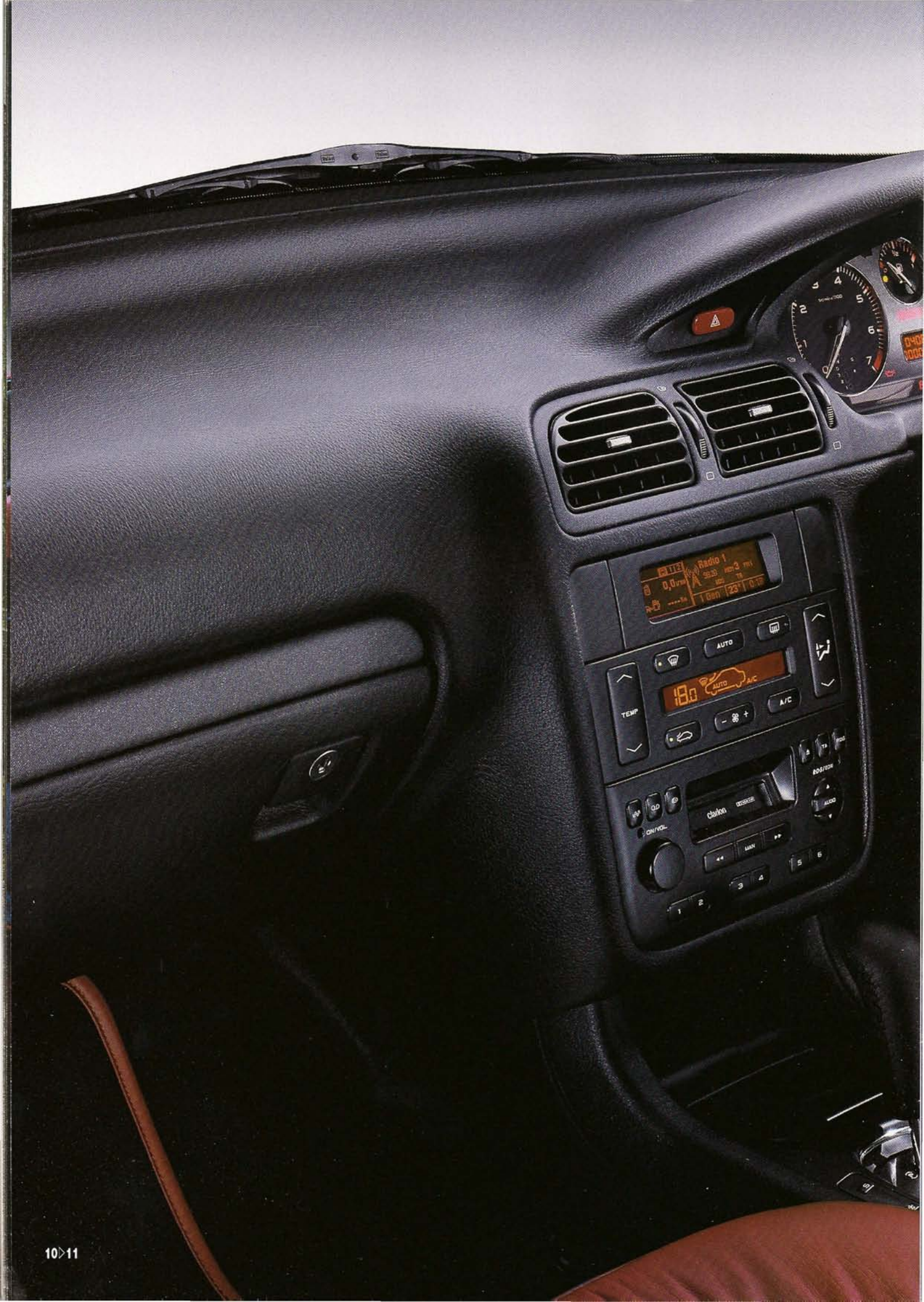

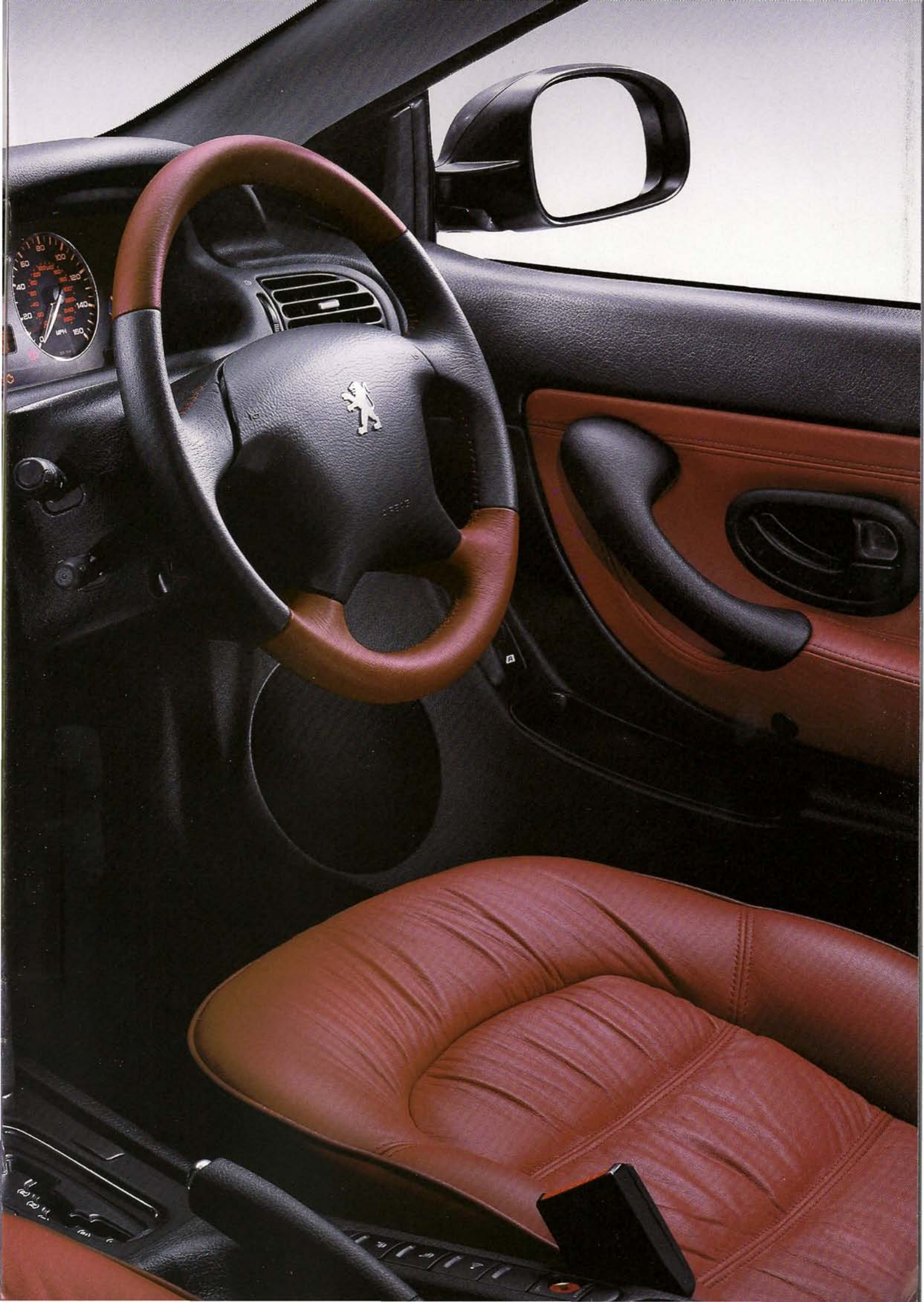



## UNDER THE BONNET: A POWER REVOLUTION

There's a lot more to the 406 Coupé than captivating looks. The choice of power includes the superb 2.2 litre HDi unit that drives like a petrol engine. Add to this the revolutionary FAP self-regenerating particulate filter that reduces particulate emissions to virtually zero – and you have world-leading technology seen for the first time in a sport Coupé.

### New 2.2 litre HDi diesel engine with particulate filter <sup>(1)</sup>

The ultra lean, ultra green, electronically managed HDi engine not only makes diesel clatter a thing of the past (it's 3dB quieter than previous engines), it makes diesel driving truly enjoyable: Torque is evenly spread right across the rev range, so response to the throttle is smooth and fast. High-pressure "common rail" fuel injection, a turbocharger and an air intake cooling exchanger enhance driving pleasure whilst dramatically reducing fuel consumption\*; the 136bhp engine returns 44.1 mpg on the combined drive cycle.

Two counterbalance shafts limit vibration and prevent resonance in the cabin, giving an impressive level of silence at any speed. And the HDi is eminently friendly to the environment: CO<sub>2</sub> emissions are reduced by 20% and carbon monoxide by 40%, with particulates down to virtually zero.

<sup>(1)</sup> Consumption MPG (litres/100 km):  
Urban drive cycle 32.1 (8.8)  
Extra urban drive cycle 57.6 (4.9)  
Combined drive cycle 44.1 (6.4)  
CO<sub>2</sub> emissions (g/km) 168

# HDi 16



## World's first self-regenerating particulate filter

The revolutionary FAP particulate filter is a porous filtration system incorporated in the catalytic converter, trapping particles of carbon when the exhaust gases pass through it. To make the filter even more effective, a special additive is automatically injected into the fuel tank every time the fuel is topped-up. The FAP filter reduces particulate and fume emissions to virtually zero, whatever the conditions in which the car is driven. The self-regenerating FAP filter also helps reduce pollutant emissions without in any way diminishing performance or driving pleasure.

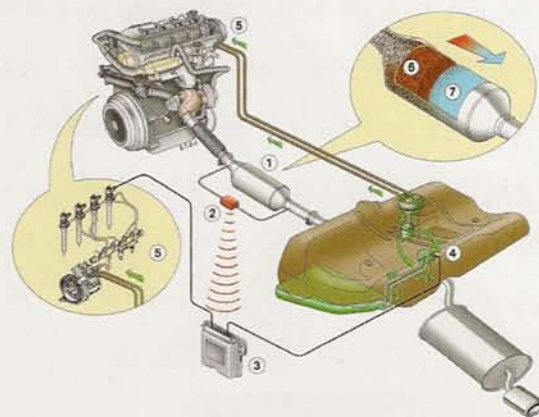

1. Catalytic converter and FAP filter
2. Sensors
3. Electronic engine management unit
4. Injection of additive into the fuel tank
5. Information sent to the injector head when post-combustion is needed for self-regeneration
6. Catalytic converter
7. FAP particulate filter

\* Please refer to the latest specification leaflet for details of economy and performance.



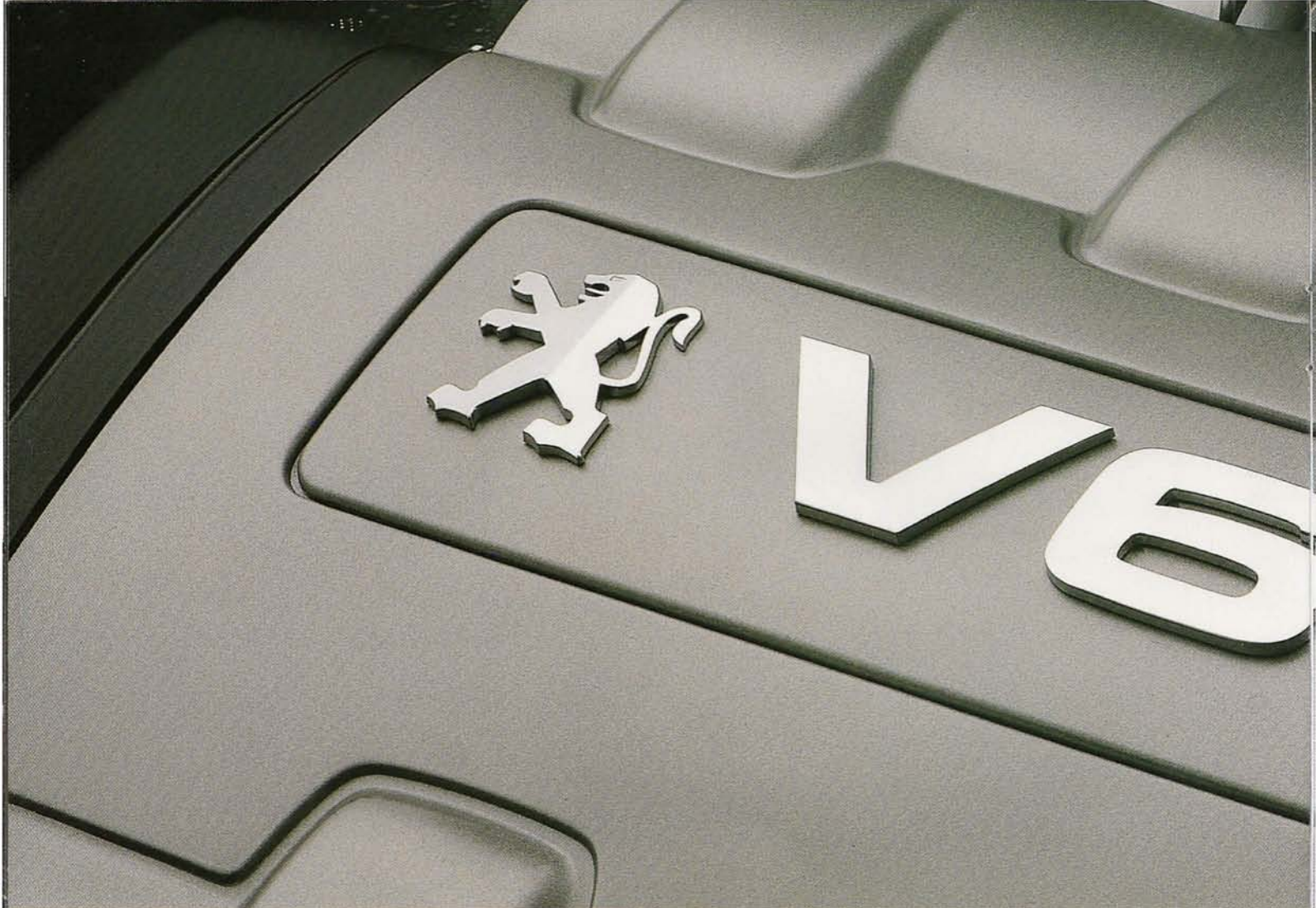

## UNDER THE BONNET: A CHOICE OF PETROL POWER

You can tailor the 406 Coupé to suit your needs.

You have the choice of two petrol power options in addition to the HDi diesel: the 138bhp 2.0 litre and the impressive 210bhp 3.0 litre V6.

Transmission options offer the clever auto-adaptive gearbox with three different drive programmes or the crisp Peugeot 5-speed manual gearbox.

### **2.0 litre 16 valve <sup>(1)</sup>**

This responsive yet economical 138bhp unit delivers 0-62 mph in 9.9 seconds, and is available with 5-speed manual or auto-adaptive gearbox.

### **3.0 litre 24 valve V6 <sup>(2)</sup>**

This remarkably quiet 210bhp power plant has variable timing and injection, so an excellent torque level is obtained at low speed. Torque at 3750 rpm is a generous 285 N/m. Despite its high performance, the engine is unfussy and unostentatious, with exceptionally smooth running. It copes easily with all the demands made on it, and its truly sporting character gives immense driving pleasure. Available with 5-speed manual or auto-adaptive gearbox.



### Auto-adaptive gearbox

This remarkable gearbox is electronically managed to adapt to any style of driving and any kind of driving conditions. It has three programmes: Auto-adaptive for normal driving, Sport for harder, more dynamic driving, and Snow for starting in second or third gear to prevent loss of grip. The gearbox also prevents the engine speed from falling too low, prevents hesitation when the engine is under load, and automatically changes down to improve deceleration in emergency braking.

<sup>(1)</sup> Consumption MPG (litres/100km):  
Urban drive cycle 24.6 (11.5)  
Extra urban drive cycle 43.5 (6.5)  
Combined drive cycle 34.0 (8.3)  
CO<sub>2</sub> emissions (g/km) 197

<sup>(2)</sup> Consumption MPG (litres/100km):  
Urban drive cycle 19.6 (14.4)  
Extra urban drive cycle 38.2 (7.4)  
Combined drive cycle 28.2 (10.0)  
CO<sub>2</sub> emissions (g/km) 238



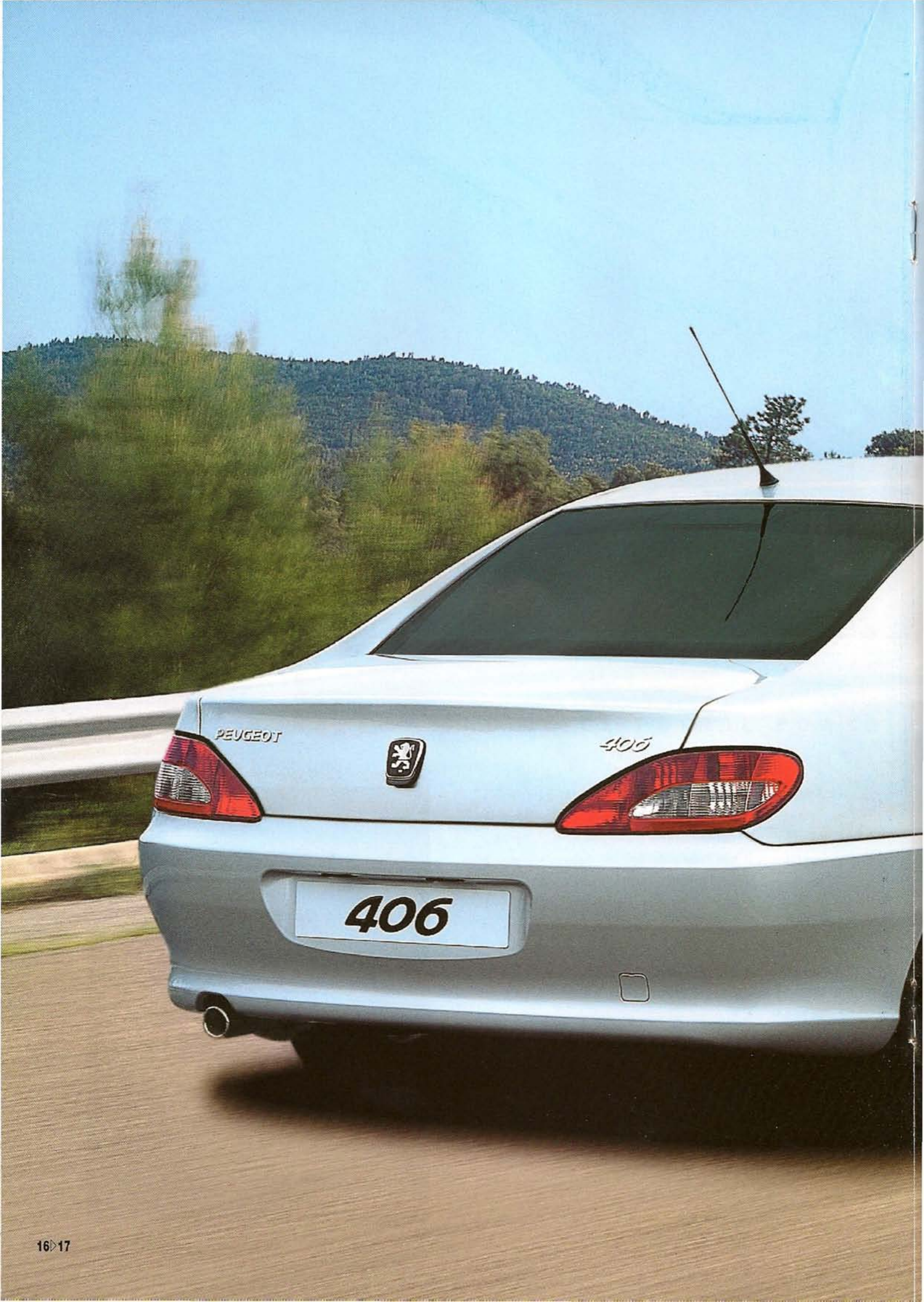

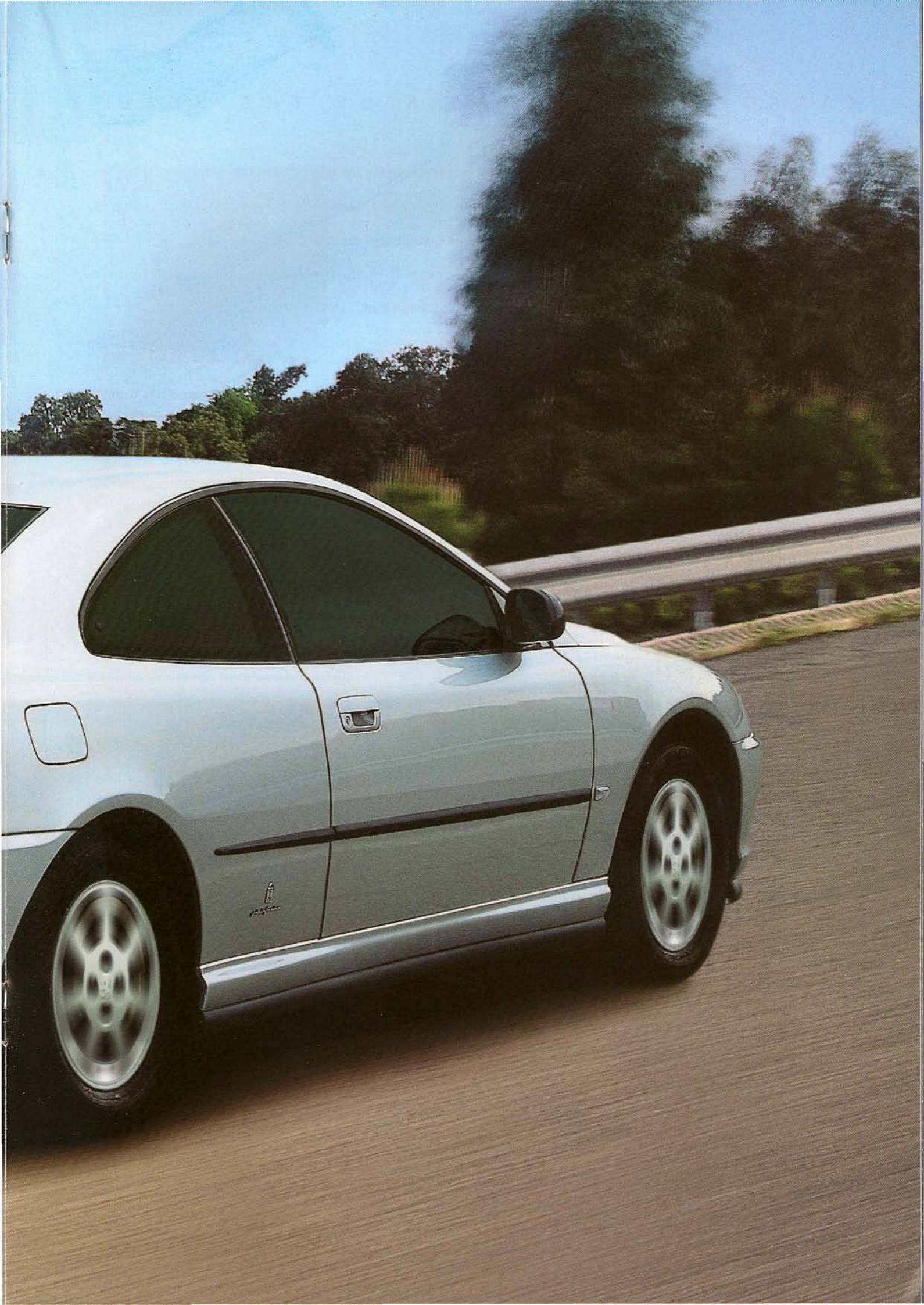



## M A N A G I N G T H E B R A I N S O F T H E B E A U T Y

The technology that gives you even more comfort, safety and pleasure calls for sophisticated electronics. Which is why multiplexing is a feature of the 406 Coupé. Multiplexing integrates all control units into a network where electrical signals are replaced by coded digital information – allowing the intelligent management of the flow of information through the vehicle. This makes it

possible for the management computer to switch on the hazard warning lights automatically in cases of emergency, to switch on the windscreen wipers when it rains, to switch on the headlights when it gets dark, and to carry out routine checks on the vehicle status (with any alerts given in visual or audible form).

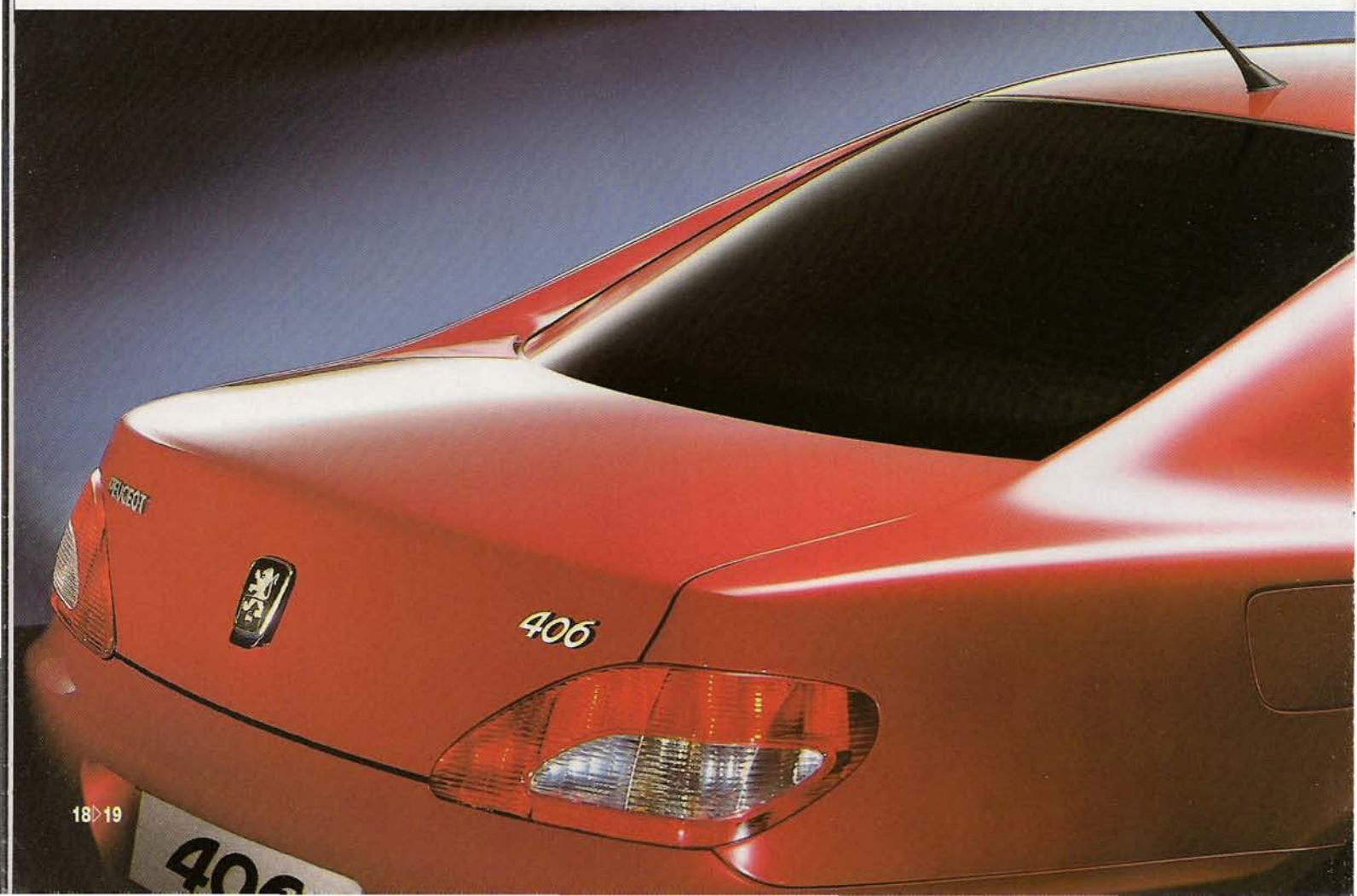



#### **Automatic headlight activation**

When the level of outside ambient light is reduced (for example at twilight, going into a tunnel or a garage, or during a rainstorm) a windscreen sensor automatically switches dipped headlights on. The headlights will turn off automatically when the external brightness increases. The driver can cancel automatic activation.

#### **Automatic hazard lights activation**

In the event of emergency braking, the hazard warning lights will be automatically switched on, allowing the driver to concentrate on the hazard, yet make following vehicles aware of the traffic situation. The hazard lights will go out automatically as soon as the driver accelerates or deactivates the system manually.



#### **Automatic wiper switch-on**

Front screen wipers are automatically switched on when it begins to rain and the speed of wiping adapts to the intensity of rain or spray. The system also allows wiping to be started manually without exiting automatic mode. If rain becomes persistent, dipped headlights will automatically switch on.

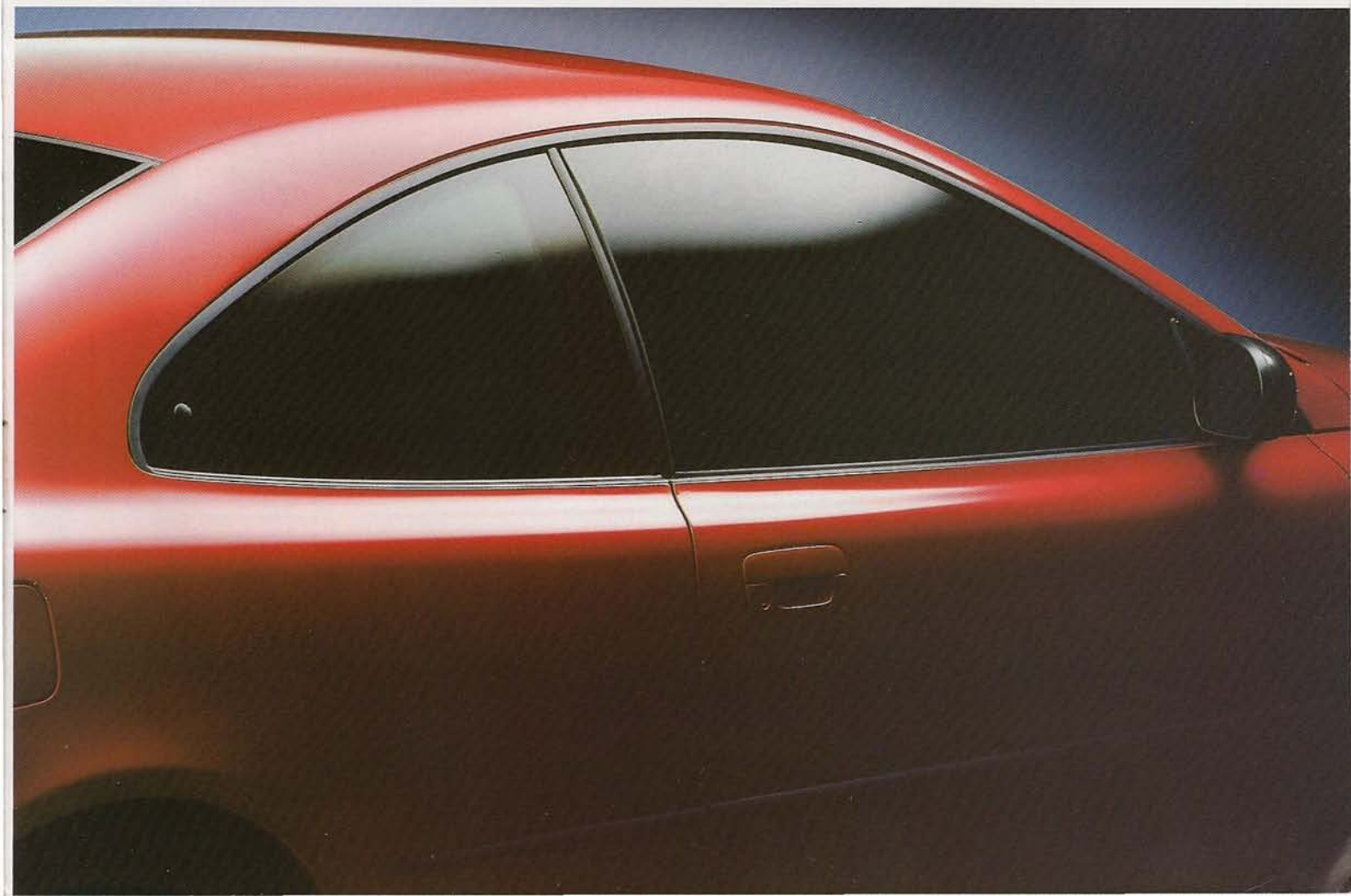



# ACTIVE SAFETY: THE COMPLETE PACKAGE

Peugeot design is recognised as the benchmark for active safety. The 406 Coupé more than upholds the Peugeot tradition, with outstandingly good road handling dynamics and performance. The multi-arm rear suspension and McPherson type front underpinnings combine with electronic brake force distribution on the ABS system to allow the driver to anticipate road conditions and react precisely.

## McPherson type front suspension

Forged steel wishbones, solid anti-roll bars and pressurised valve dampers are specifically adapted to the dynamics of the 406 Coupé.

The suspension is characterised by its high levels of comfort and precision, providing greater driving pleasure and safety.

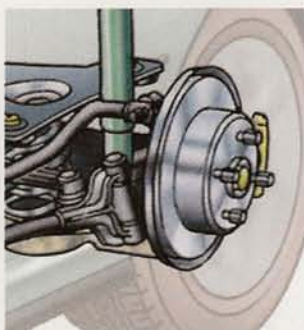

## Multi-arm rear suspension

Three transverse half-arms give each wheel stability and efficiency under load, with a longitudinal arm guaranteeing maximum comfort in all situations.

The suspension ensures exemplary road performance.

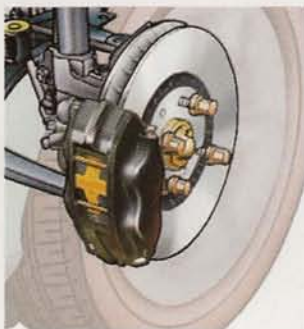

## Variable power steering

Variable power steering ensures that the light handling needed in town driving is complemented with the more solid feel you need on the open road. The system adapts to engine speed on 4-cylinder versions, and to road speed on V6 versions.

## ESP (Electronic Stability Programme)

This advanced programme has four functions: ABS, electronic brake force distribution, traction control and dynamic stability control, which give the car optimum balance. A sensor in the centre of the car compares its line on the road with the one desired by the driver and if there's a significant difference, the system brakes one or more wheels and adjusts engine torque to return the car to the right line.

## ABS with Electronic Brake Force Distribution

The ABS system standard on all 406 Coupé models prevents the wheels locking and allows the driver to maintain his line even if emergency braking is needed. Electronic Brake Force Distribution is linked into the ABS system to distribute brake pressure over all four wheels for maximum stability, depending on the road grip and vehicle load.

## An amplification of the braking pressure

Emergency Brake Assist is provided in addition to ABS. Activated by pressing firmly on the brake pedal, the mechanical system amplifies the pressure to utilise the full braking potential of the vehicle.

## Brembo 4-piston caliper brakes on 2.2 HDi and 3.0 V6 versions

Formula 1 braking specialists Brembo have designed a system that gives drivers precision handling and superbly quick deceleration.

# PASSIVE SAFETY: EVEN MORE PEACE OF MIND

Cleverly planned innovation and solidly tested features build the highest levels of passive safety into the 406 Coupé. The reinforced body structure, side airbags incorporated in the seats and exceptional road handling give driver and passengers real security.

## Advanced technology adaptive front airbags

The new generation front airbags in the 406 Coupé are designed to adapt sensitively to different impact conditions. Sensors and internal generators precisely adapt inflation speed and pressure to the impact. Driver and front passenger airbags are complemented by side airbags specially designed to protect the head and thorax.



## Front seat belts

The front seat belts are fitted with a pyrotechnic pre-tensioning system. On impact, a powder cartridge pulls the belt in by ten centimetres, securing the occupant back against the seat. A force limiter then activates to minimise the tension, reducing compression of the thorax to the minimum.

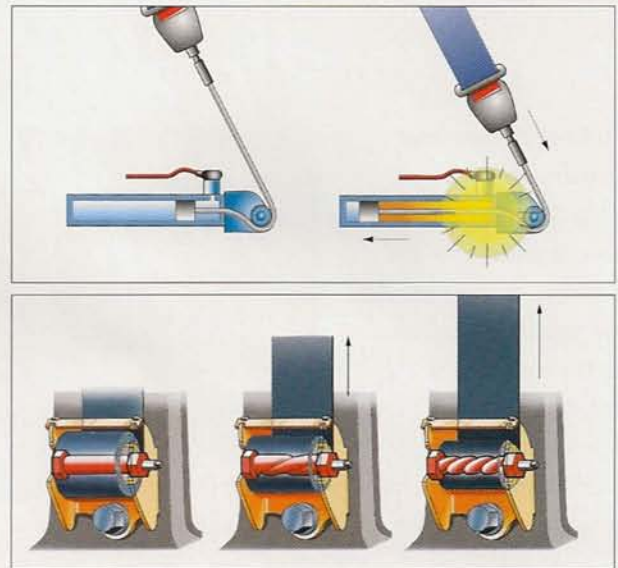

Front seat belts

## Programmed deformation

Better protection and impact resistance is assured by programmed deformation structure design and a central roof cross member which is boxed in to provide head protection. Reinforced pillars, strong door padding and side member stiffeners give effective side impact protection.

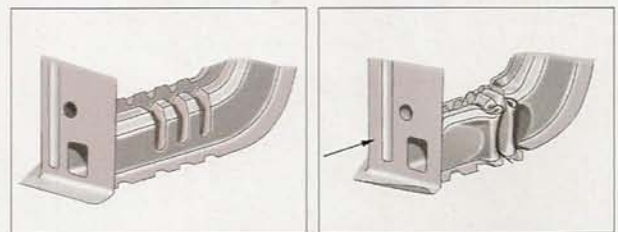

Programmed Deformation Structure

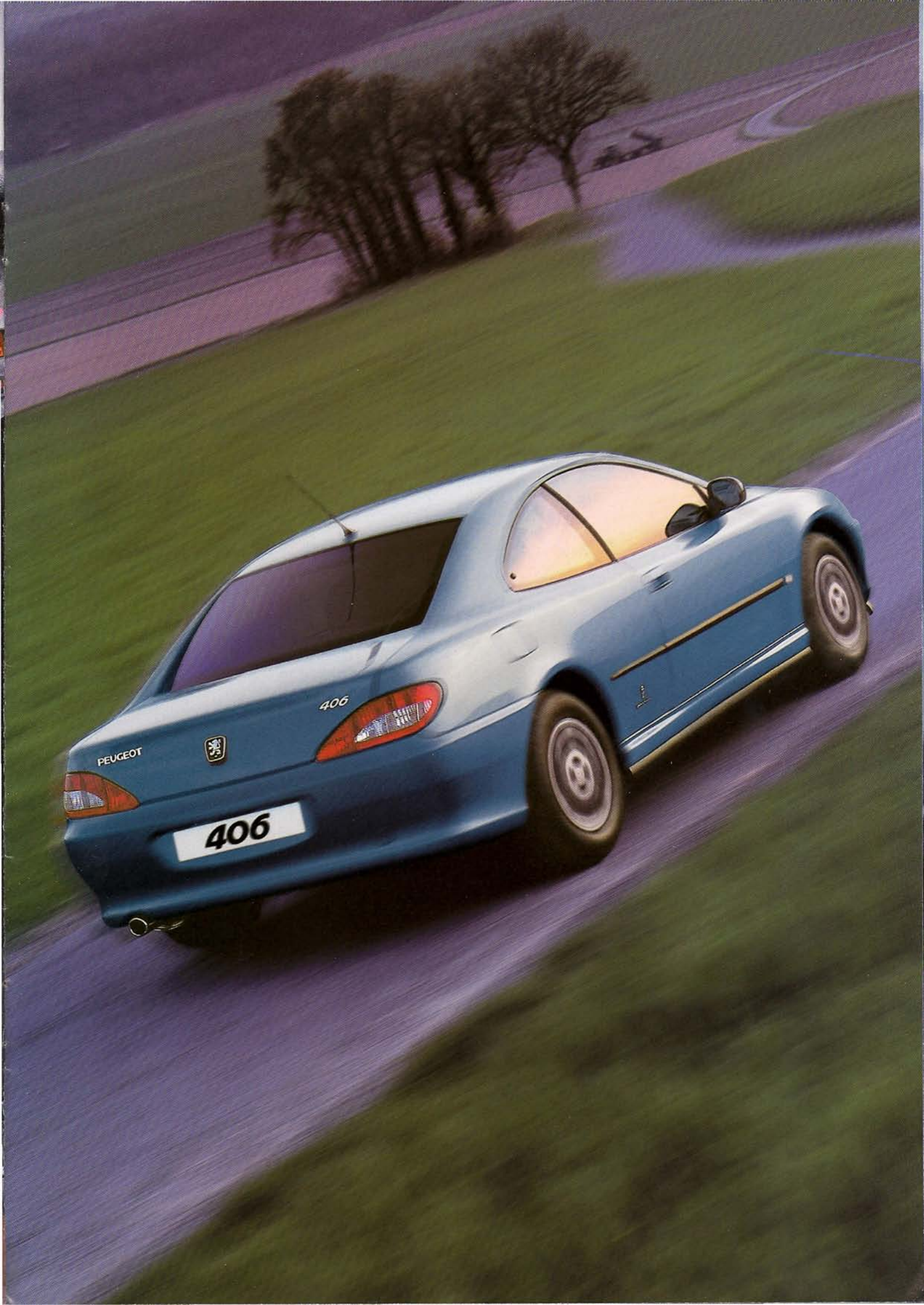

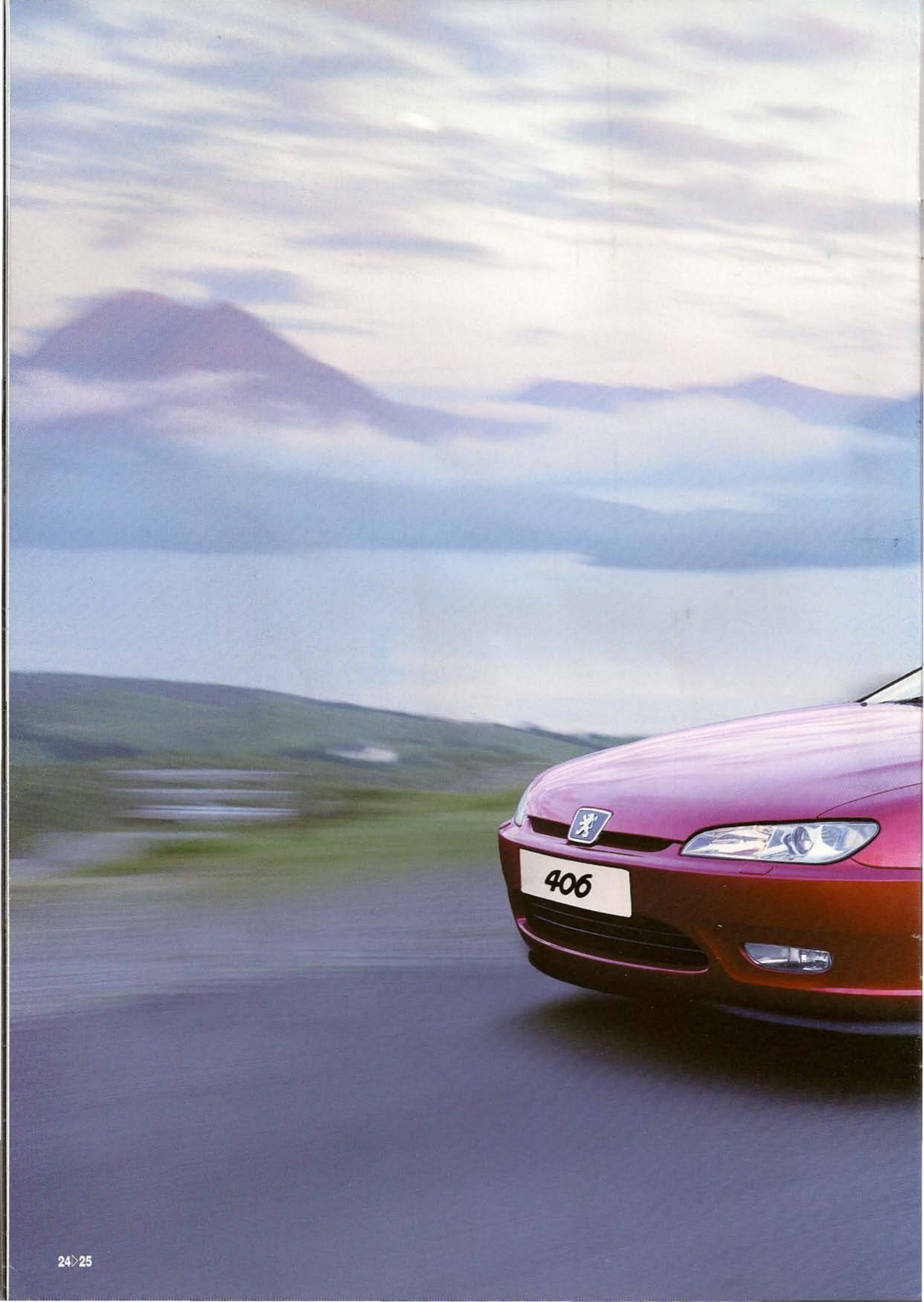

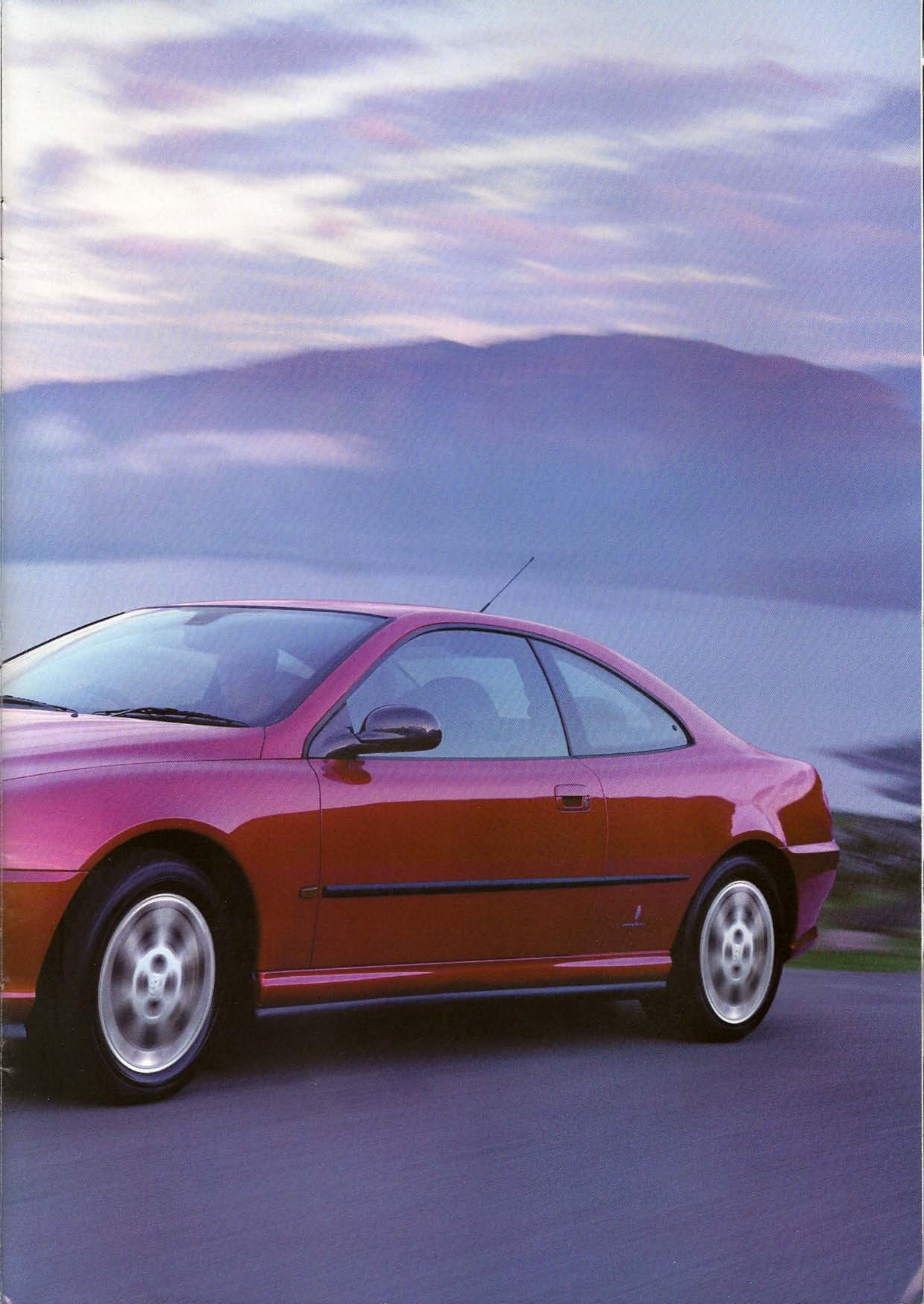



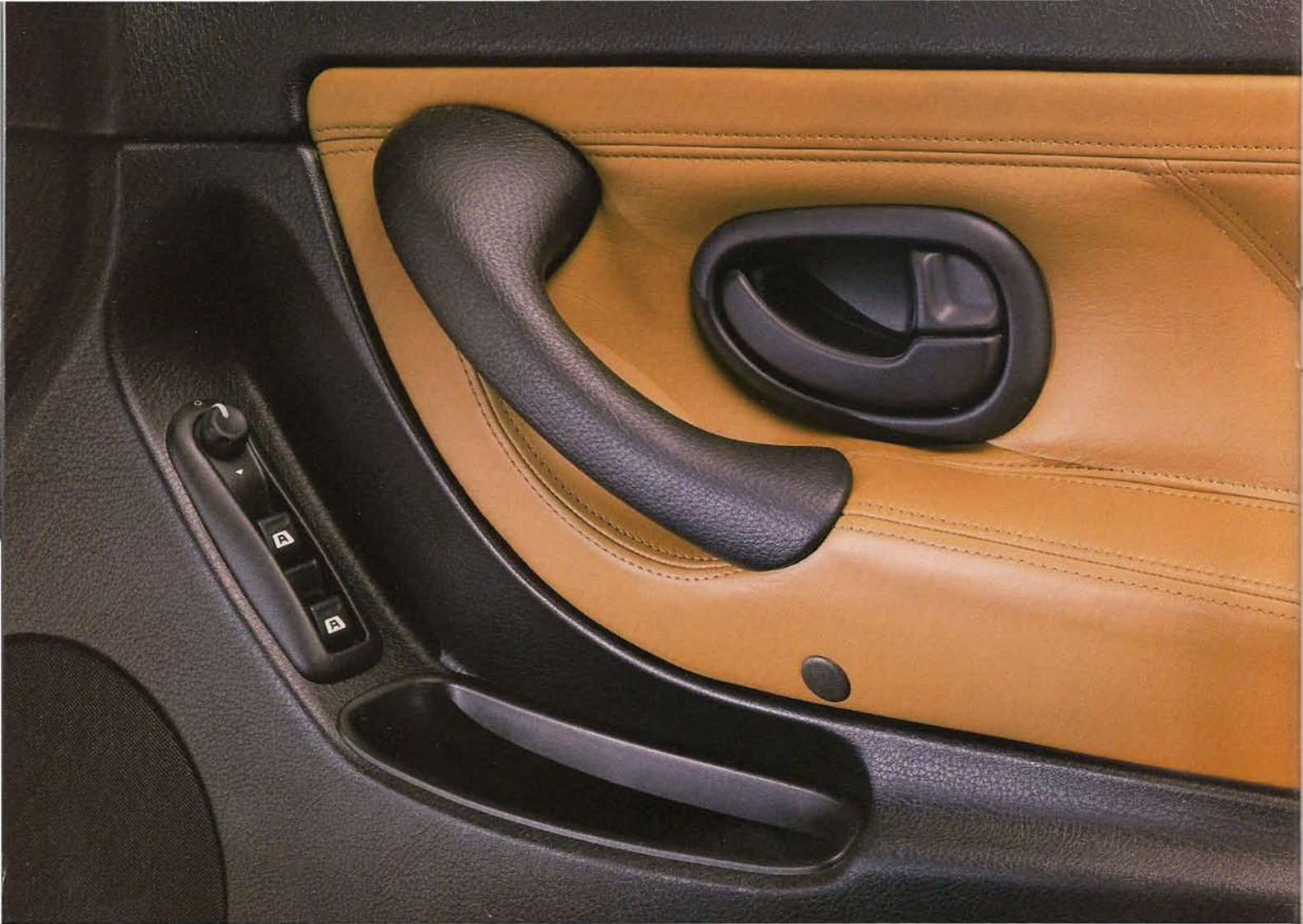

# C A B I N   C O M F O R T   Y O U ' L L   A P P R E C I A T E

Classy, sporty, distinctive: the cabin of the 406 Coupé is tailored for today. The dash panel epitomises quality, strength and safety, with easy-to-read sporty dials stylishly circled in chrome. The display panel

groups all the car's functions, and all settings are ergonomically located. The brushed aluminium gearlever knob, metallic finishes and top quality trim all emphasise real distinction.



Sport front seats and rear bucket seats are standard; on SE versions, the front seats are electrically operated and heated, with two-position memory setting for the driver's seat.

For in-car entertainment at its very best, a JBL 10-speaker amplifier and graphic equaliser system is an extra cost option on the S model and standard equipment on the SE.

The Clarion RM2 audio system and 6-disc CD autochanger are linked to a separate graphic equaliser which enriches acoustic signals and delivers 320 watts to ten top of the range speakers, precisely placed in the eight best positions identified in the original body design concept.



The Satellite Navigation System (optional on S versions, standard on SE) guides the driver to his chosen destination through visual display and voice instructions. The advanced system integrates GPS information, continuous transmission of vehicle positioning and the CD-Rom drive for road maps.



# AND YOUR FINAL SELECTION



Polaris Blue\*



Hyperion Blue\*



Galileo Green



Diablo Red\*



Scarlet Red



Cosmos Grey\*



Satellite Grey\*



Solstice Gold\*

You've been captivated by the looks. You've chosen the model you want. Now all you've got to do is personalise the car... Should you match Black Mugello cloth upholstery with Diablo Red? Or Tungsten leather interior to complement Hyperion Blue? Take your time. A 406 Coupé is a long-term driving partner.



Hoggar 16" alloy wheels



Black Mugello Cloth



Grey Mugello Cloth



Tungsten Leather



Amarante Red Leather



Chestnut Leather

\* Metallic/Pearlescant paint is an option at extra cost.



**406**

## 406 coupé accessories

You can fully personalise your 406 Coupé by choosing from our extensive range of accessories, just six of which are shown here.

From the sporty rear spoiler or styled mudflaps, to the practical cycle carrier or towbars, the 406 Coupé accessories help make your drive even more enjoyable, while helping to protect your car from wear and tear. For details of the full range of 406 Coupé accessories please ask for a copy of the 406 Accessory Brochure.

### 1. Centre console armrest

The hinged armrest opens to reveal a spacious storage area.

### 2. Luxury Carpet Mats

Black luxury mats embossed with Coupé badge.



### 3. Swan Neck Towbar

Quick release towbar available with single or double electrics.



### 4. Styled Mudflaps

Designed to compliment the lines of the vehicle whilst protecting its bodywork from damage that can be caused by road debris. They can be colour coded for a sporty look.

### 5. Boot Mounted Rear Spoiler

Designed to compliment the vehicle's styling, the 406 Coupé spoiler adds that extra sporty look.

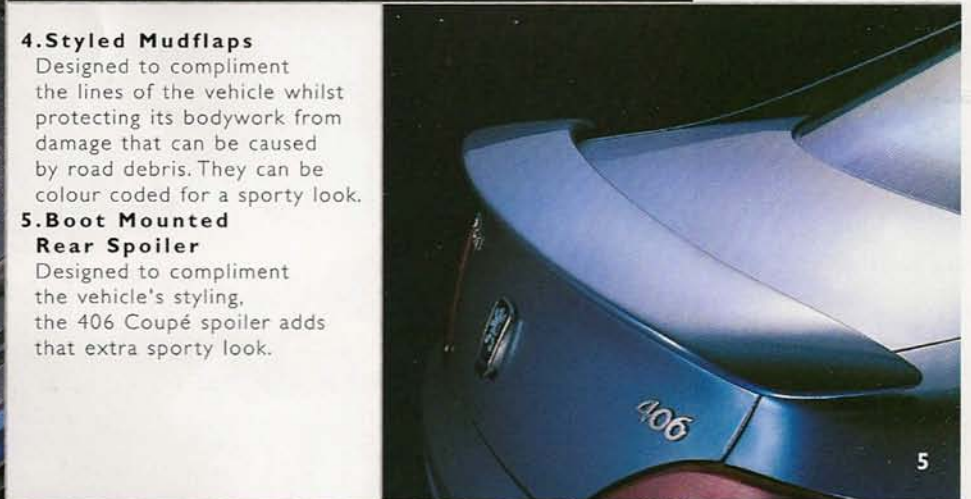

### 6. Rear Boot Mounted Cycle Carrier

Suitable for carrying two cycles (30kg max)

NB to comply with vehicle lighting regulations this product should be used with a lighting board.



---

## **The Peugeot Customer Promise**

---

When you buy a new Peugeot vehicle from a Peugeot Dealer in the UK and entrust your vehicle to one of them for servicing or repair, they promise:

- to give you the best people, with the best training and diagnostic tools;
- genuine Peugeot parts and the best aftersales backup;
- all at a competitive price.

### **Peugeot Peace of Mind**

Peugeot vehicles are designed and manufactured to give you worry-free motoring and peace of mind. As a Peugeot owner you are entitled to a comprehensive range of customer care services from your Peugeot Dealer who has the expertise to maintain your Peugeot to its peak performance.

### **Peugeot Warranties**

#### **3 Years of Warranty**

In addition to the Peugeot one year unlimited mileage manufacturer's warranty, all vehicles first registered in the UK and purchased from a UK Peugeot Dealer on or after January 1<sup>st</sup> 2001 benefit from a free optional two years of warranty provided by the Peugeot Dealer network in the UK. This optional Warranty is offered free of charge but subject to the manufacturers recommended servicing being carried out by an authorised franchised Peugeot dealership. This additional warranty carries a mileage limit of 60,000 miles from first registration. Otherwise the conditions of the additional warranty are identical to those of the one year manufacturer's warranty. (For full terms and conditions, please consult your Peugeot Dealer. This 3 years of warranty is automatically transferable on sale of the vehicle).

#### **12 Year Anti-Perforation Warranty on Cars**

Also automatically transferable on sale of the vehicle, this will maintain and enhance the resale value of your vehicle. (The Anti-Perforation Warranty is limited to 6 years on Partner, Expert and Boxer vans).

#### **3 Year Paint Warranty on Cars**

The Paint Warranty has been extended to 3 years on cars, again totally transferable without charge. (The Paint Warranty is limited to 1 year on Partner, Expert and Boxer vans).

#### **Peugeot Extended Warranty**

Should you need protection beyond the initial 3 years of warranty, the Peugeot Extended Warranty plan can give you cover of up to 120,000 miles and 4 or 5 years. Available as an option at extra cost, the Peugeot Extended Warranty is one of the most competitive schemes of its type and is available exclusively to Peugeot owners. Please ask your Dealer for full details.

#### **Peugeot Assistance**

For the first year of ownership you will automatically receive Peugeot Assistance cover for complete peace of mind. Additional Peugeot Assistance may be purchased for the second and third

years. Operated by the AA, it includes European cover, roadside assistance, vehicle recovery, free replacement car or hotel accommodation and chauffeur provision in case of certain medical disabilities. Peugeot Assistance is available within the UK and Europe. Your local Peugeot Dealer has full details of terms and conditions.

### **Peugeot Service Care**

Peugeot petrol engine vehicles need servicing every 20,000 miles or every 2 years, whichever is sooner. Drivers of diesel versions also benefit from extended servicing with 10,000 miles or 2 year intervals and 2 years or 12,000 miles for HDi turbo diesel vehicles. With less time spent in the maintenance bay and fewer service visits, Peugeot have passed on the benefits of technology in engine design and lubrication. Cost savings compared to competitive models increase with mileage covered, and could be up to 45%.

In order to minimise the inconvenience associated with normal servicing, Peugeot UK Dealers promise to offer you the choice of:

- while you wait servicing with a timed appointment;
  - or local vehicle collection from your home or place of work;
  - or alternative transport to the railway station, home or place of work; or by arrangement, a hire car at a concessionary rate.
- In addition, they will undertake to ensure that your vehicle is washed before it is returned.

### **Peugeot Insurance**

Peugeot Insurance has been specifically arranged for Peugeot owners. Offering discounted premiums and a fast and efficient claims service, it is another benefit of owning a Peugeot. You can call the Peugeot Insurance Centre direct on 0345 333 500 for a free quotation. Alternatively, log onto the Peugeot website at [www.peugeot.co.uk](http://www.peugeot.co.uk) for an online insurance quotation in just six questions. Whatever Peugeot you drive, we guarantee to beat your current insurer's renewal premium on a like-for-like basis (this does not apply to any current policy issued by the Peugeot Insurance Centre).

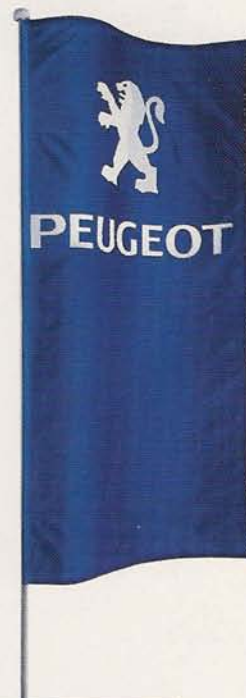



**Green Marathon Programme.** With their partners, the National Forestry Commission and Pro Natura International, Peugeot are engaged in a massive programme of re-forestation in the Amazon. The purpose of the programme (which consists of over 5000 hectares/12350 acres of Amazonian Territory) is to create and maintain for 40 years a real "carbon sink" of 10 million trees. This will absorb excess CO<sub>2</sub> from the atmosphere as well as reducing CO<sub>2</sub> concentration and controlling the emissions of greenhouse gases. Unique in its scale, duration, objectives and resources invested, this programme christened "Green Marathon" complements the steps taken to reduce the emissions of Peugeot vehicles and demonstrates in a practical and exemplary manner the marque's approach to the environment.

To find out more visit:  
<http://environnement.peugeot.com>

For details of Diplomatic and Export Sales, contact Peugeot Export,  
454-490 Mile End Road, London, E1 4PE

ISSUED BY SALES AND MARKETING, PEUGEOT MOTOR COMPANY PLC,  
ALDERMOOR HOUSE, PO BOX 227, ALDERMOOR LANE, COVENTRY, CV3 1LT

Peugeot **0845 200 1234** (calls charged at local rate)  
[www.peugeot.co.uk](http://www.peugeot.co.uk)

The information and images in this brochure are based on the current technical data when going to press. The equipment shown is factory-fitted or available as an option at extra cost, depending on the model. As part of a policy of continuous specification improvement, Peugeot reserve the right to modify the technical equipment, options and colours at any time. The cars featured may contain specification combinations that are not available in the UK. For full specification details please refer to the specification leaflet or ask your Peugeot Dealer, who will be happy to help. Note that current print and photographic techniques do not allow us to faithfully reproduce the full depth and tone of the colours in this brochure. This brochure is designed to provide general product information and is not a contractual document or offer of sale. For current information, please contact your nearest franchised Peugeot Dealer. The details in this catalogue cannot be reproduced without the express authorisation of Peugeot.

YOUR PEUGEOT DEALER IS:

SEPTEMBER 2001



**PEUGEOT**

MCP 1865